

Sep.1.2017 Copyright 2017 HIROSE ELECTRIC CO., LTD. All Rights Reserved.

NOTES. 1 THIS PRODUCT, EXCEPT PLUG UNIT AND SHIELD CASE UNIT A1, ARE PACKED SEPARATELY BY THE TYPES OF PARTS.

2. RECOMMENDED CABLE IS HITACHI METALS CO., LTD. UL20276-SB 4PX28AWG (7/0.127) LF. PLEASE REFER TO THE TECHNICAL SPECIFICATION SHEET ETAD-E3143 ABOUT CABLE ASSEMBLY METHOD.

3 BUILT-IN DIRECTION OF THE PART NO.3, THERE ARE TWO DIRECTIONS TO BE SHOWN. THERE IS NO PROBLEM IN THE PERFORMANCE IN EITHER CASE.

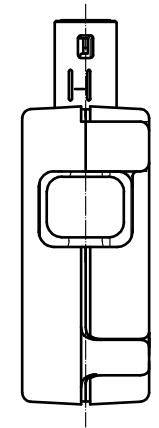
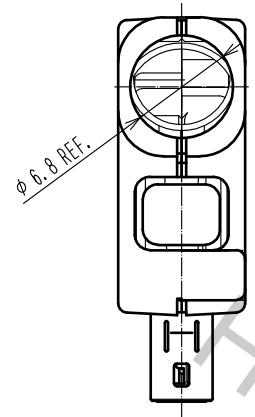
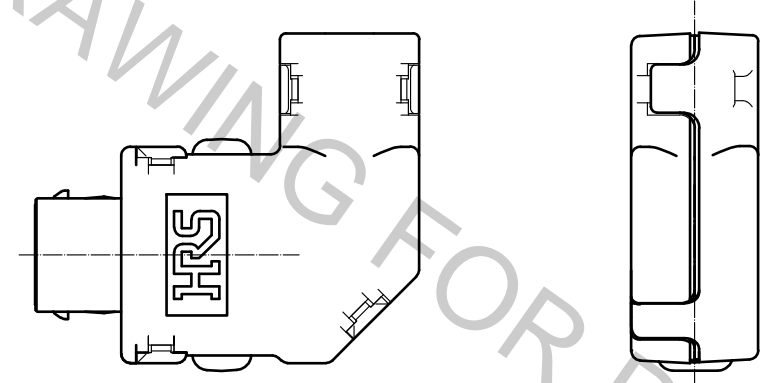
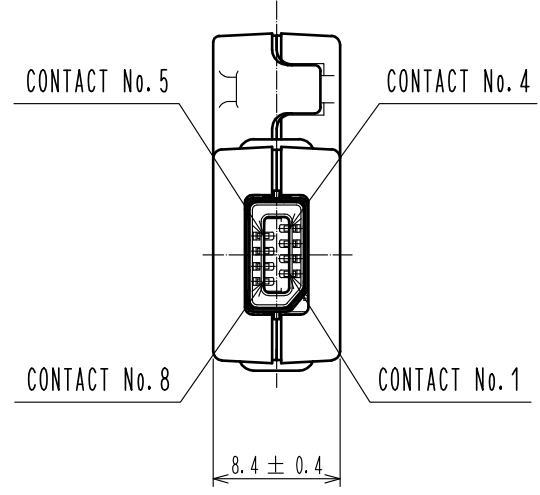
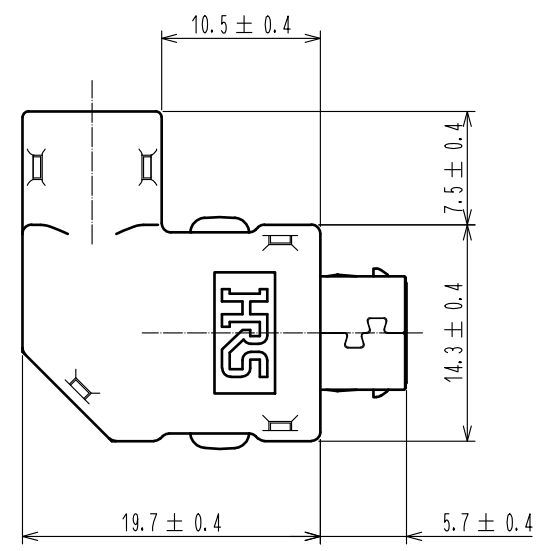

MATED CONDITION(FREE)

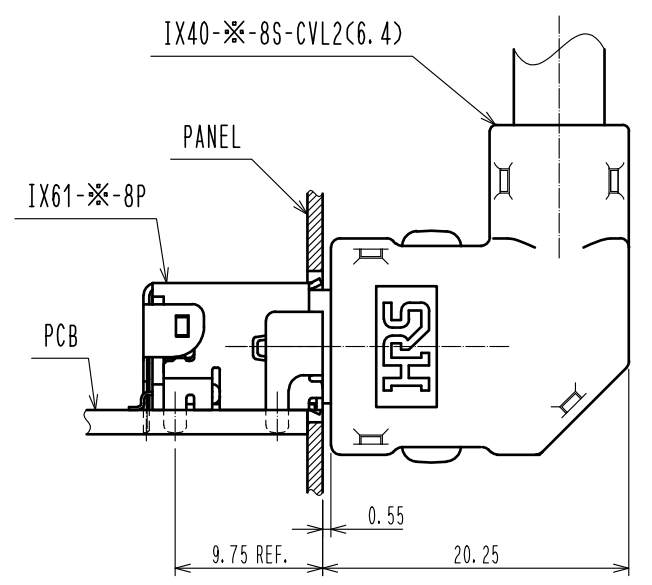

UNMATED CONDITION(FREE)

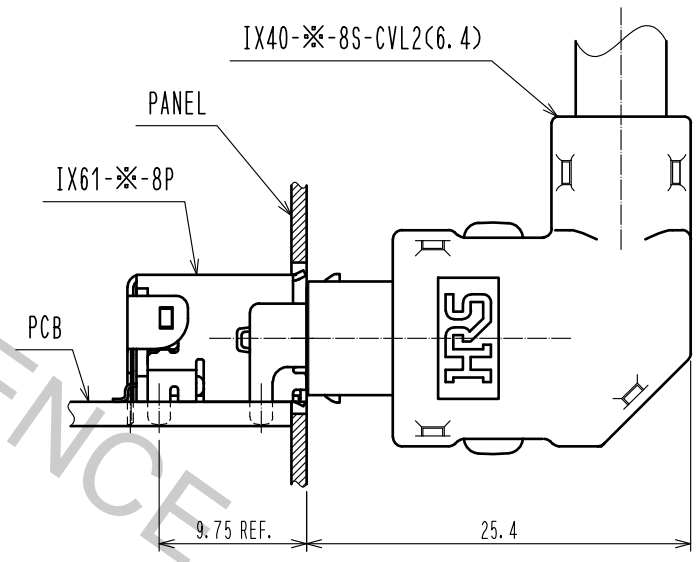

4	STAINLESS STEEL	NICKEL 2 μm min.	9	PC	BLACK, UL94V-0
3	LCP	BLACK, UL94V-0	8	PC	BLACK, UL94V-0
2	PA	BLACK, UL94V-0	7	PBT	BLACK, UL94V-0
1	COPPER ALLOY	CONTACT AREA : GOLD 0.2 μm min.	6	STAINLESS STEEL	NICKEL 2 μm min.
		LEAD AREA : GOLD 0.03 μm min.	5	STAINLESS STEEL	NICKEL 2 μm min.
		UNDER PLATING : NICKEL 2 μm min.			
NO.	MATERIAL	FINISH . REMARKS	NO.	MATERIAL	FINISH . REMARKS
UNITS mm		SCALE 2 : 1	COUNT 	DESCRIPTION OF REVISIONS	
APPROVED : NM. NISHIMATSU 15.12.08			DESIGNED	CHECKED	
CHECKED : NM. NISHIMATSU 15.12.08			DATE		
DESIGNED : TS. SAKAIZAWA 15.12.08			DRAWING NO. EDC-128673-00-00		
DRAWN : TS. SAKAIZAWA 15.12.08			PART NO. IX40-A-8S-CVL2(6.4)		
			CODE NO. CL251-0003-8-00		
			1/2		

Sep.1.2017 Copyright 2017 HIROSE ELECTRIC CO., LTD. All Rights Reserved.

1 PACKING COMPOSITION

3 DIRECTION OF THE PART No. 3(FREE)

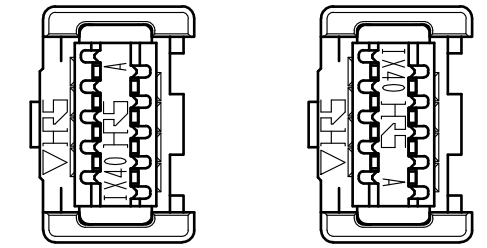
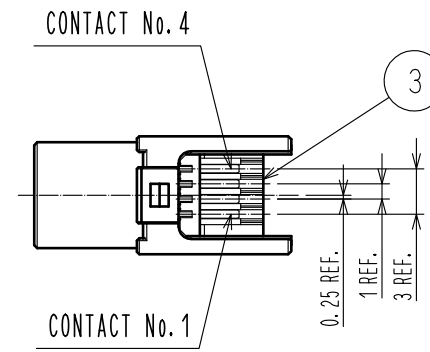
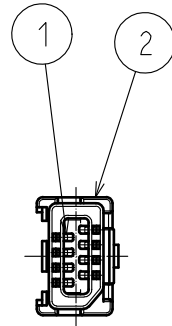
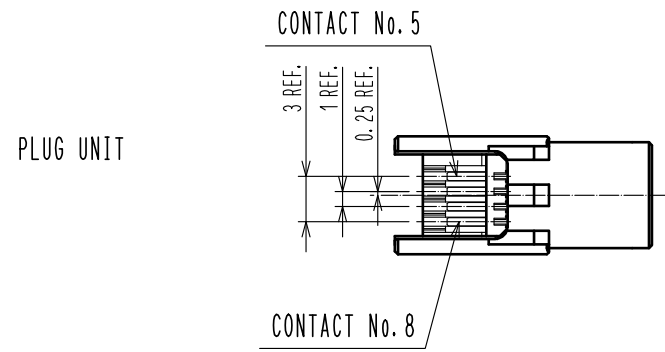

S SHELL

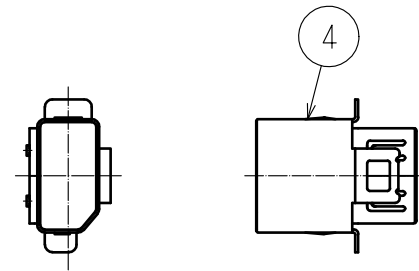

SHIELD CASE A2 UNIT

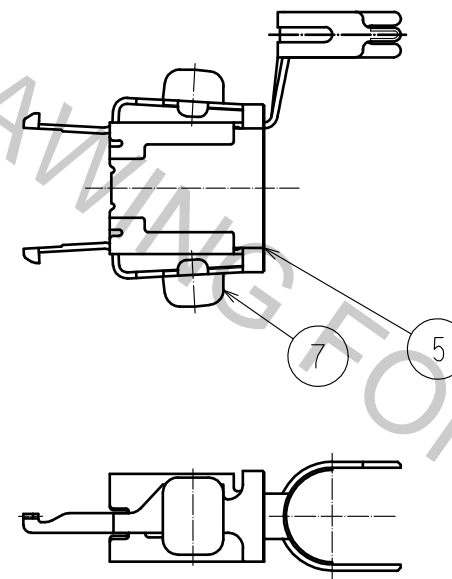

SHIELD CASE B

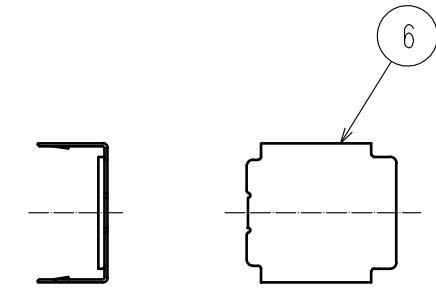

COVER CASE A

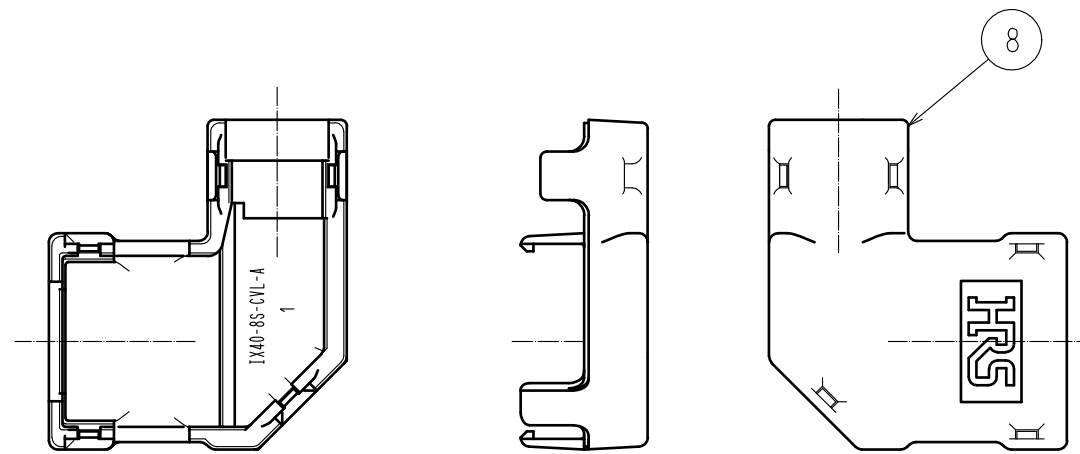

COVER CASE B

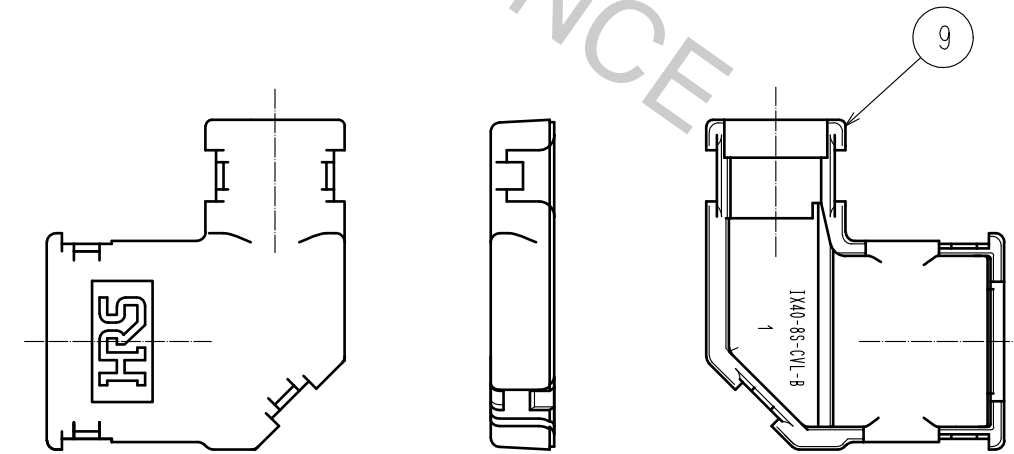

HRS	DRAWING NO.	EDC-128673-00-00		2/2
	PART NO.	IX40-A-8S-CVL2(6.4)		
	CODE NO.	CL251-0003-8-00		