

NOTES. 1 THIS PRODUCT, EXCEPT PLUG UNIT AND SHIELD CASE UNIT A1, ARE PACKED SEPARATELY BY THE TYPES OF PARTS.

2. RECOMMENDED CABLE IS HITACHI METALS CO., LTD. UL20276-SB 4PX28AWG (7/0.127) LF.
PLEASE REFER TO THE TECHNICAL SPECIFICATION SHEET ETAD-E3143 ABOUT CABLE ASSEMBLY METHOD.

3 BUILT-IN DIRECTION OF THE PART NO. 3, THERE ARE TWO DIRECTIONS TO BE SHOWN.
THERE IS NO PROBLEM IN THE PERFORMANCE IN EITHER CASE.

MATED CONDITION(FREE)

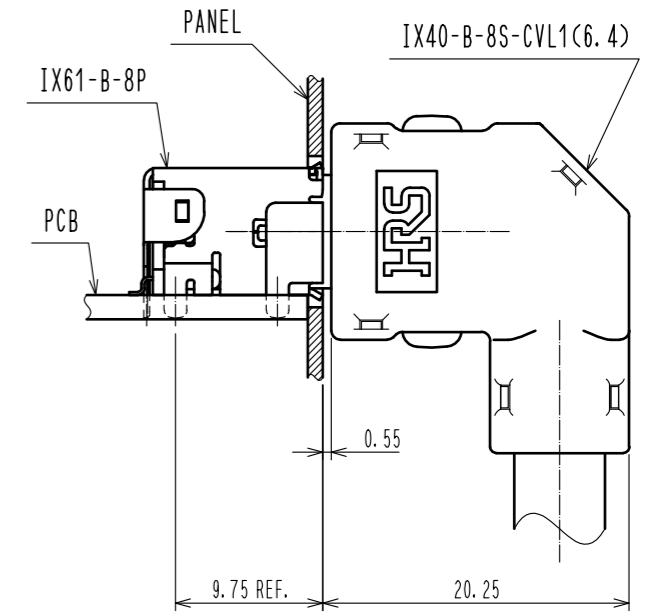

UNMATED CONDITION(FREE)

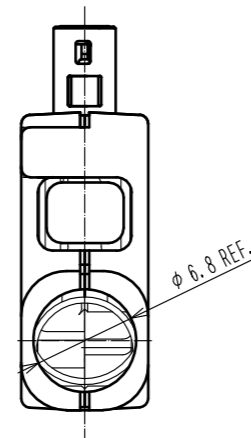
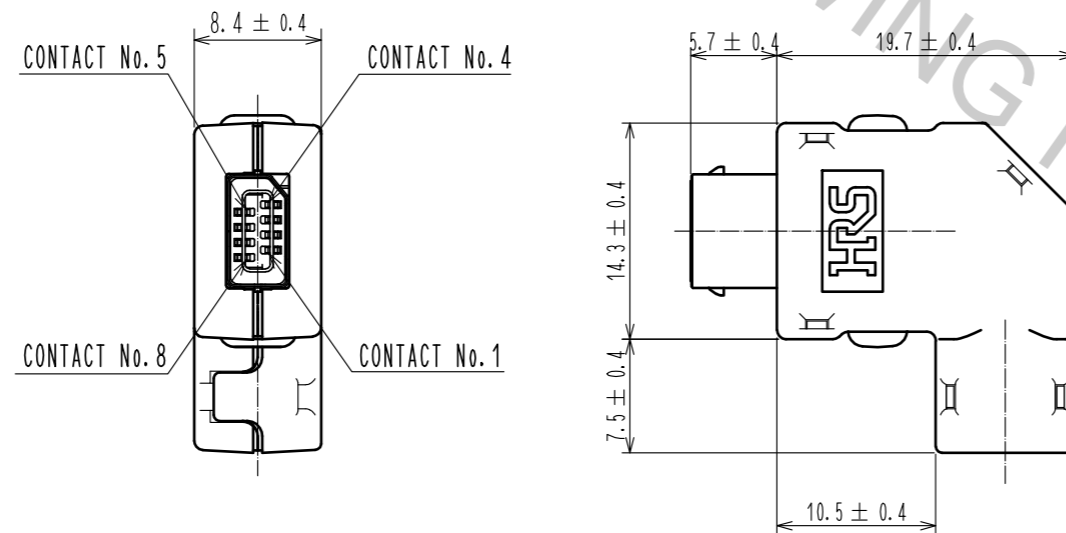
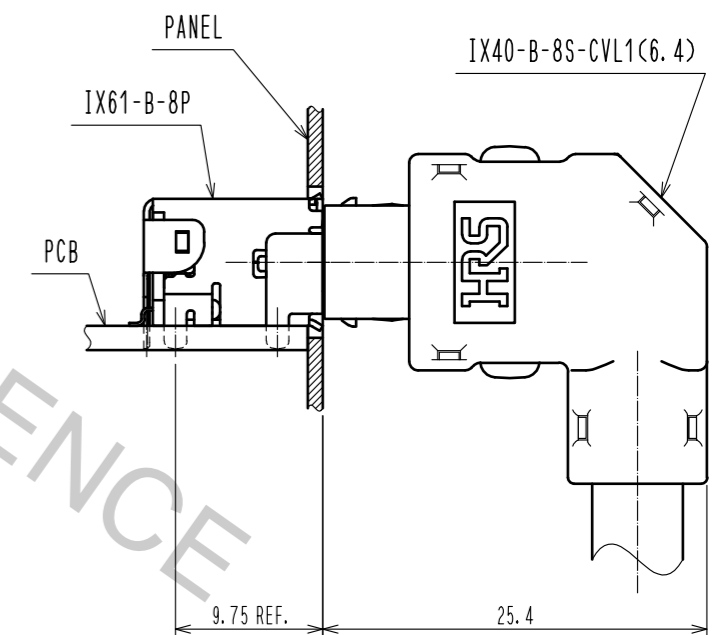

4	STAINLESS STEEL	NICKEL 2 μm min.	9	PC	BLACK, UL94V-0			
3	LCP	BLACK, UL94V-0	8	PC	BLACK, UL94V-0			
2	PA	BLACK, UL94V-0	7	PBT	BLACK, UL94V-0			
1	COPPER ALLOY	CONTACT AREA : GOLD 0.2 μm min.	6	STAINLESS STEEL	NICKEL 2 μm min.			
		LEAD AREA : GOLD 0.03 μm min.	5	STAINLESS STEEL	NICKEL 2 μm min.			
	UNDER PLATING : NICKEL 2 μm min.							
NO.	MATERIAL	FINISH . REMARKS	NO.	MATERIAL	FINISH . REMARKS			
UNITS mm		SCALE 2 : 1	COUNT 	DESCRIPTION OF REVISIONS		DESIGNED	CHECKED	DATE
			APPROVED : NM, NISHIMATSU	16.05.14	DRAWING NO. EDC-129115-00-00			
HIROSE ELECTRIC CO., LTD.			CHECKED : NM, NISHIMATSU	16.05.14	PART NO. IX40-B-8S-CVL1(6.4)			
			DESIGNED : P, EKSOURIYA	16.05.14	CODE NO. CL251-0009-0-00			
			DRAWN : P, EKSOURIYA	16.05.14				

Sep.1.2017 Copyright 2017 HIROSE ELECTRIC CO., LTD. All Rights Reserved.

1 PACKING COMPOSITION

3 DIRECTION OF THE PART NO.3(FREE)

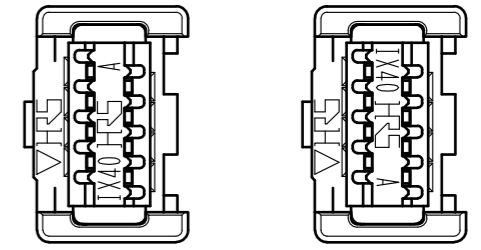
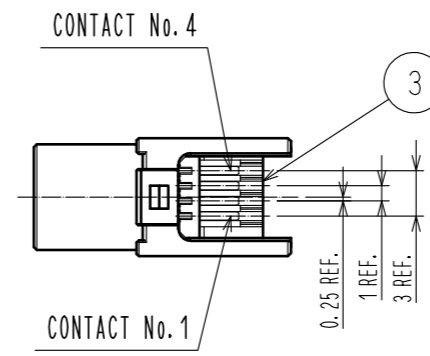
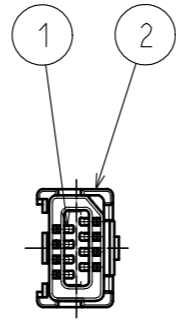
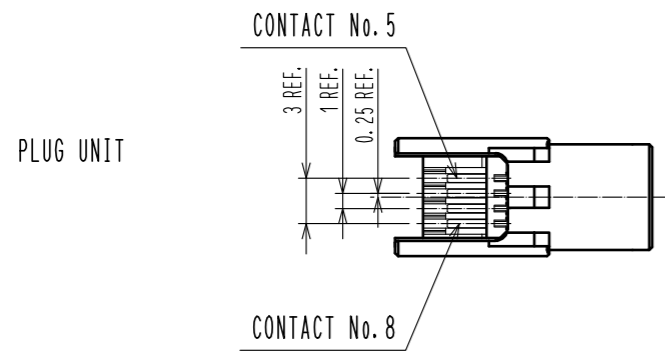

S SHELL

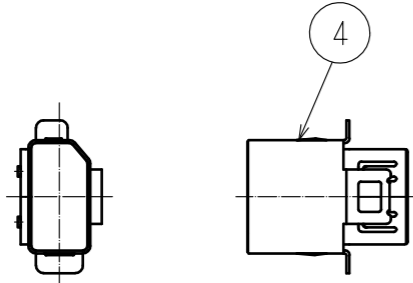

SHIELD CASE UNIT A1

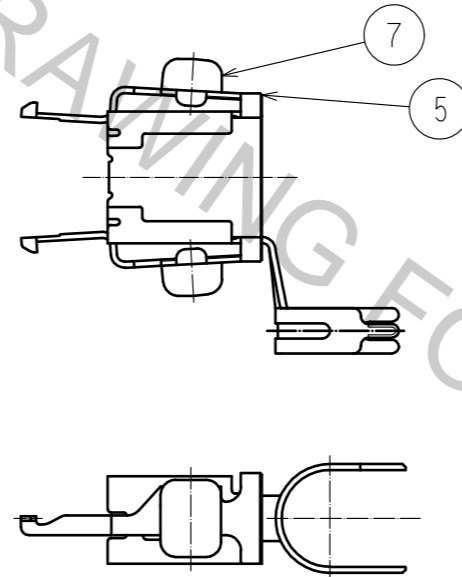

SHIELD CASE B

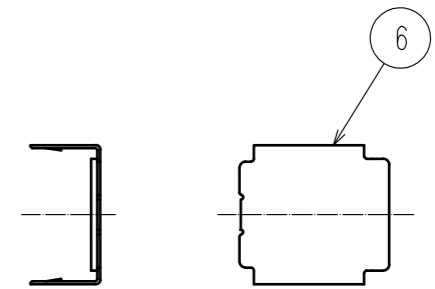

COVER CASE A

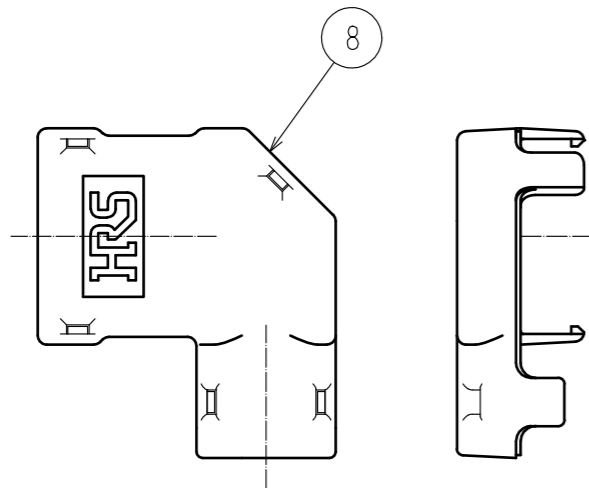

COVER CASE B

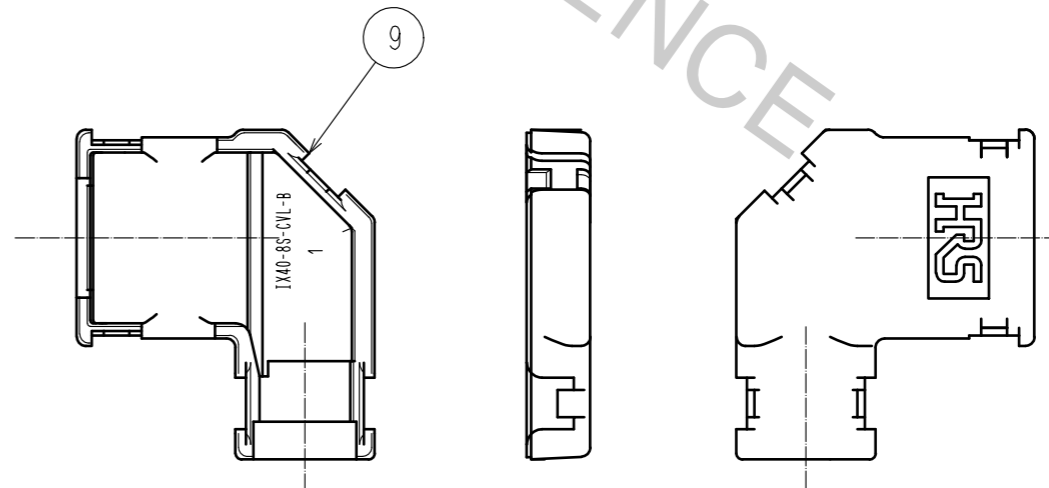

HRS	DRAWING NO.	EDC-129115-00-00
	PART NO.	IX40-B-8S-CVL1(6.4)
	CODE NO.	CL251-0009-0-00
		2/2